

Polycom VVX 411

Phone User Guide



February 2018

Confidentiality

All information in this document is provided in confidence as per the terms and conditions of HV.Select and shall not be published or disclosed wholly or in part to any other party without HV.Select prior permission in writing. These obligations shall not apply to information which is published or becomes known legitimately from some source other than HV.Select.

Version Control

This document is controlled and issued by the HV.Select Product Manager. Please ensure that you have the latest version of this document, existing Communications Providers (CP) can download this from the HV.Select Document Centre, and new customers should check with their Account Managers.

Description of change	Issue	Date
Published version for launch	Final 1.0	February 2018



Confidentiality	1
Version Control	2
Polycom VVX 411	7
WHC IP Phone User guide	7
Overview of Phone Hardware and Keys	11
<i>VVX 400 Series Hardware</i>	11
Navigating VVX Business Media Phones	13
<i>Accessing Screens on VVX 411Phone</i>	13
<i>Access the Home Screen</i>	13
<i>Access the Calls Screen</i>	13
<i>Access the Lines Screen</i>	14
<i>Access the Active Call Screen</i>	14
<i>Switch Among Phone Screens</i>	15
<i>Icons and Status Indicators</i>	15
Audio Calls	16
<i>Placing and Answering Audio Calls</i>	17
<i>Placing Audio Calls</i>	17
<i>Place a Call from the Dialer</i>	17
<i>Place an International Call</i>	17
<i>Place a Call from Recent Calls</i>	17
<i>Calling Favorites</i>	18
<i>Call Favorites from the Favorites List</i>	18
<i>Call Favorites from the Home or Lines Screen</i>	18
<i>Calling Contacts from the Directory</i>	18
<i>Call a Contact from a Directory</i>	18
<i>Redial a Number</i>	19
<i>Redial a Contact when the Contact is Available</i>	19
<i>Answering Audio Calls</i>	19
<i>Answer an Incoming Call</i>	19
<i>Answer a Call from the Calls Screen</i>	20
<i>Answer a Call When in a Call</i>	20
<i>Switch Among the Handset, Headset, and Speakerphone</i>	20
<i>Mute and Unmute Audio</i>	21
<i>Holding and Resuming Calls</i>	21
<i>Hold a Call</i>	21
<i>Resume a Call</i>	21

<i>Ending Calls</i>	21
<i>End an Active Audio Call</i>	21
<i>End a Held Call</i>	22
<i>Transferring Calls</i>	22
<i>Choose a Default Transfer Type</i>	22
<i>Transfer a Call</i>	22
<i>Cancel a Transfer</i>	23
<i>Managing Calls</i>	23
Display Calls from the Lines Screen	23
<i>Display Calls from the Calls Screen</i>	23
<i>Manage a Call from the Calls Screen</i>	23
<i>Ignoring or Rejecting Incoming Calls</i>	24
<i>Ignore or Silence an Incoming Call</i>	24
<i>Reject Incoming Calls</i>	24
<i>Reject Calls from a Contact</i>	24
<i>Rejecting Calls with Do Not Disturb</i>	25
<i>Enable Do Not Disturb</i>	25
<i>Reject Calls with Do Not Disturb on Multiple Lines</i>	25
<i>Reject Calls with Do Not Disturb on One Line</i>	25
<i>Disable Do Not Disturb</i>	26
<i>Redirecting Incoming Calls</i>	26
<i>Forwarding Incoming Calls to a Contact</i>	26
<i>Forward an Incoming Call to a Contact</i>	26
<i>Forward All Incoming Calls to a Contact</i>	26
<i>Disable Call Forwarding</i>	27
<i>Divert Calls to a Contact</i>	27
Conference Calls	27
<i>Tips for Conference Calls</i>	27
<i>Audio Conference Calls</i>	28
<i>Initiate a Conference Call</i>	28
<i>Join Calls to Create a Conference Call</i>	28
<i>End a Conference Call</i>	29
Hold a Conference Call	29
<i>Resume a Conference Call</i>	29
<i>Split a Conference Call</i>	29
<i>Manage Conference Call Participants</i>	29



Call Lists and Directories	30
<i>Recent Calls</i>	30
<i>View Recent Calls</i>	30
<i>Sort Recent Call Entries</i>	31
<i>Sort Entries by Call Type</i>	31
<i>Edit a Recent Call Entry</i>	31
<i>Delete a Recent Call Entry</i>	31
<i>Save a Recent Call Entry</i>	31
<i>View Call Details</i>	32
<i>Contact Directory</i>	32
<i>Search for a Contact in the Contact Directory</i>	32
<i>Add a Contact to the Contact Directory</i>	32
<i>View Contact Information</i>	33
<i>Update a Contact's Information</i>	33
<i>Delete a Contact from the Contact Directory</i>	33
<i>Corporate Directory</i>	33
<i>Searching the Corporate Directory</i>	34
Perform a Quick Search of the Corporate Directory	34
Perform an Advanced Search of the Corporate Directory	34
<i>Save Corporate Directory Search Results</i>	34
<i>Clear Corporate Directory Search Results</i>	34
<i>Add Corporate Directory Contacts to the Contact Directory</i>	35
Favorites and Contact Lists	35
<i>Managing Favourites</i>	35
<i>Add Favourites</i>	35
<i>Viewing Favourites</i>	35
<i>View Favourites</i>	35
<i>View Favorites from the Lines Screen</i>	36
<i>Reorder Favorites</i>	36
<i>Delete Favorites</i>	36
Phone Accessories and Computer Applications	36
<i>Using a Headset with Your Phone</i>	37
<i>Connecting a Headset</i>	37
<i>Use Your Headset for All Calls</i>	37
<i>Reactivate Headset Memory Mode</i>	37
<i>Using Electronic Hookswitch</i>	38



<i>Setting the Headset Base Unit Options</i>	38
<i>Enable Electronic Hookswitch</i>	38
<i>Change the Headset Mode</i>	38
<i>Controlling Calls with Electronic Hookswitch</i>	39
<i>Disconnect Your Headset</i>	39
Accessibility Features	39
<i>Features for Hearing-Impaired Users</i>	39
<i>Accessibility Features for Hearing-Impaired Users</i>	39
<i>Features for Mobility-Impaired Users</i>	40
<i>Accessibility Features for Mobility-Impaired Users</i>	40
<i>Features for Vision-Impaired and Blind Users</i>	41
<i>Accessibility Features for Vision-Impaired and Blind Users</i>	41
General information	42

Polycom VVX 411

WHC IP Phone User guide



Polycom VVX® 300 and 400 Series Quick Start Guide



Note: For more information on your Polycom® VVX® 300 series and VVX 400 series business media phones, see user documentation, including Quick User Guides and User Guides, on your phone's Support page on Polycom Voice Support: http://support.polycom.com/PolycomService/support/us/support/voice/business_media_phones/

Package Contents

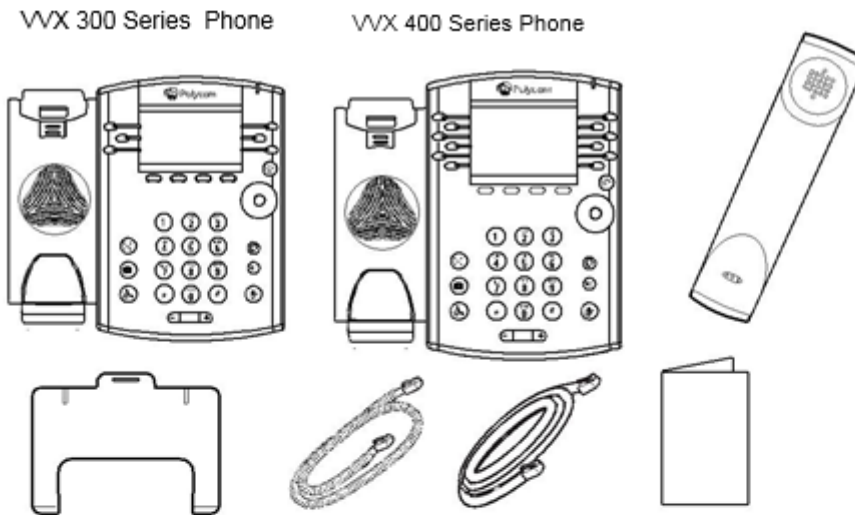

Optional Accessories

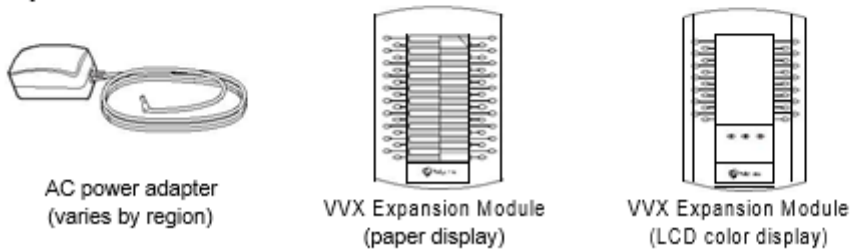

For more information, contact your reseller.

Features

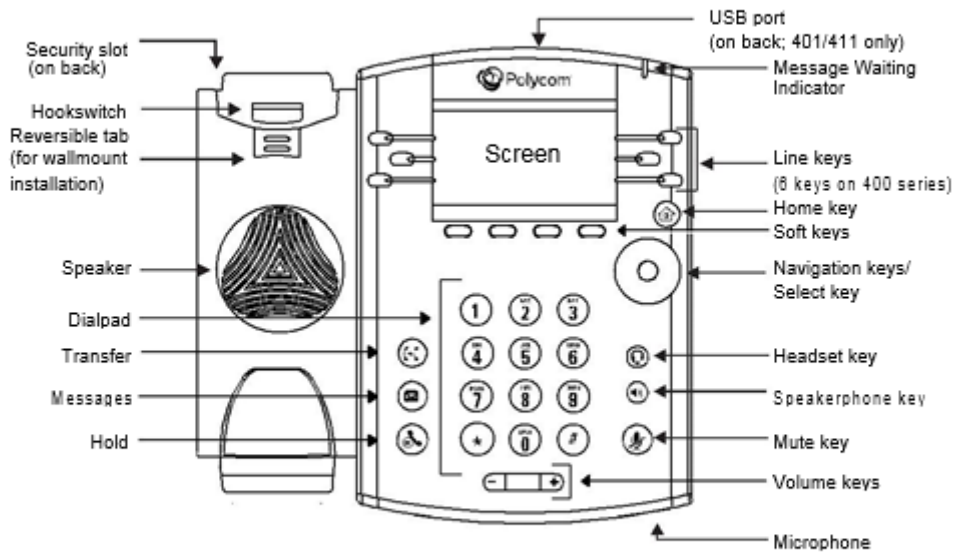

Connect Cables

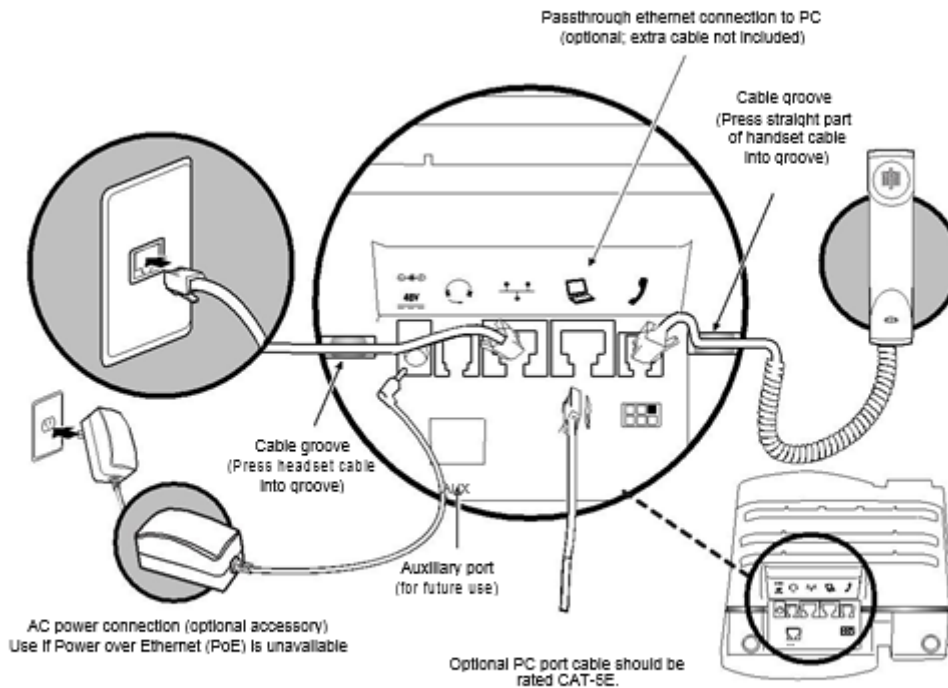

Connect Stand*

Fully insert the stand into one of the slots on the back of the phone. The slot you choose determines the angle of the phone.

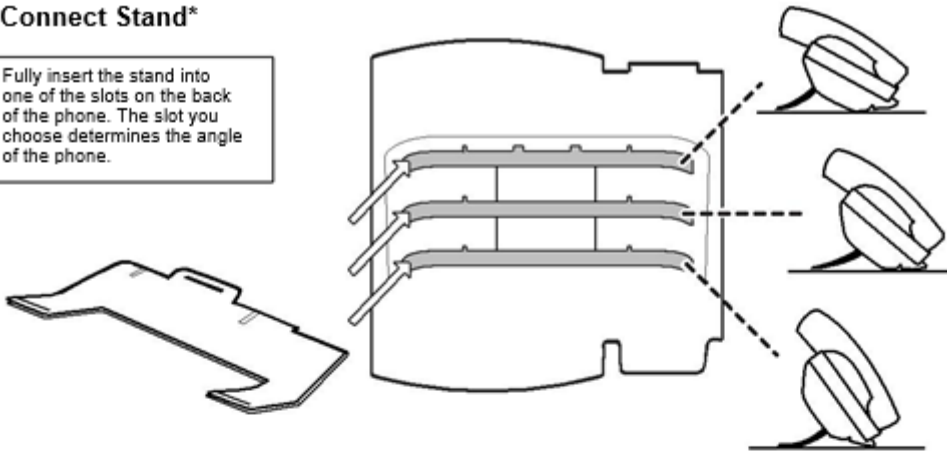

*For wallmount installation, an optional accessory is available. For more information, contact your reseller.

Connect Optional Headset

Note: Your phone supports wired headsets, including electronic hookswitch (EHS) headsets. For connection directions, refer to your headset documentation. Standard headsets typically use the RJ-9, while EHS headsets use the RJ-9 and serial port.

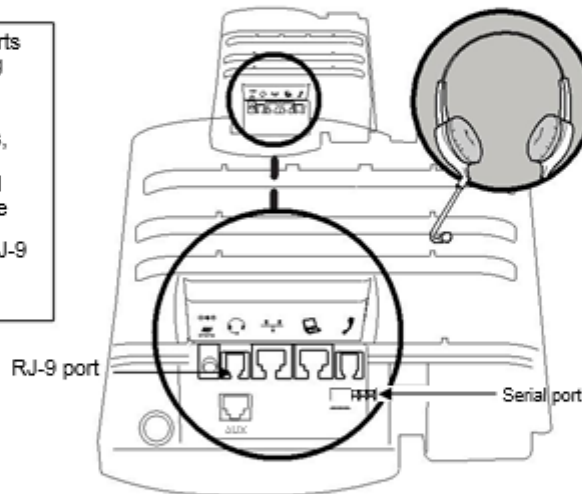

Connect Optional USB Devices

On VVX 401/411 phones, you can attach a USB headset, or a USB flash drive to record calls, use the Digital Picture Frame feature, or to change the background picture on your phone. To learn more, see your phone's User Guide.

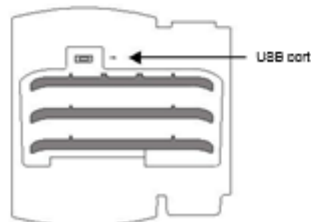

Overview of Phone Hardware and Keys

Use the following figures and tables to understand your VVX phone's hardware features.

VVX 400 Series Hardware

The following figure displays the hardware features on the VVX 400, 401, 410, and 411 business media phones. The table lists each feature numbered in the figure.

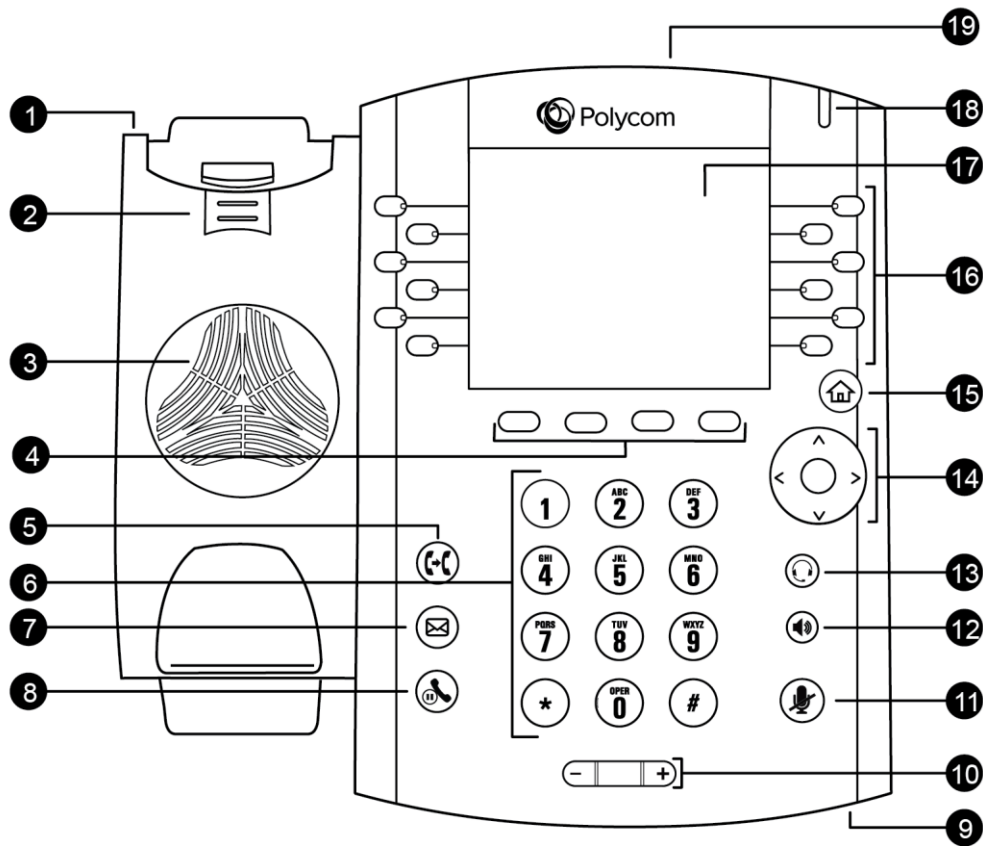



Reference Number	Feature	Feature Description
1	Security slot (on top)	Enables you to attach a universal security cable lock to your phone so you can secure it to a desktop.
2	Reversible tab	Secures the handset in the cradle when your phone stand is positioned at a high angle. To secure the handset, remove the tab, reverse it so the protrusion points up, and re-insert it. Position the handset so the protrusion on the tab fits into the slot on the handset.
3	Speaker	Provides ringer and speakerphone audio output.
4	Soft keys	Enable you to select context sensitive keys that display along the bottom of the screen.
5	Transfer key	Transfers an active call to a contact.
6	Dialpad keys	Enable you to enter numbers, letters, and special characters. You can also use the dialpad keys to select menu items that have index numbers.
7	Messages key	Enables you to access and manage instant and voice messages.
8	Hold key	Holds an active call or resumes a held call.
9	Microphone	Transmits audio to other phones.
10	Volume keys	Adjust the volume of the handset, headset, speaker, and ringer.
11	Mute key	Mutes local audio during calls and conferences. The key glows red when activated.
12	Speakerphone key	Enables you to place and receive calls using the speakerphone. The key glows green when activated.
13	Headset key	Enables you to place and receive calls through a headset. The key glows green when an analog headset is activated, and blue when a USB headset is activated.
14	Navigation key/ Select key	Scrolls through information or options displayed on the phone's screen. Selects a field of displayed data.
15	Home key	Displays the Home screen from other screens, and displays the Lines and Calls screens from the Home screen.
16	Line keys	Enable you to select a phone line, view calls on a line, or quickly call a favorite contact.

17	Screen	Shows a 3.5-inch (8.89 cm) diagonal screen with a backlight that enables you to view menus and data.
18	Message Waiting Indicator	Flashes red to indicate when you have new messages.
19	USB Port	Enables you to attach a USB flash drive or USB headset (VVX 411 only).

Navigating VVX Business Media Phones

The phone has icons, status indicators, and user screens to help you navigate and understand important information on the state of your phone.

Accessing Screens on VVX 411Phone

You can access the following screens on the phone:

- Home Screen—Displays your messages, settings, and information.
- Calls Screen—Displays all active and held calls on your line.
- Lines Screen—Displays your phone lines, favorites, and conditional soft keys.
- Active Call Screen—Displays the active call currently in progress.

Access the Home Screen

On the VVX 411 phone, the phone lines and icons you can select to access phone features, settings, and information display on the Home screen.

The following figure shows the Home screen on VVX 411 phones

Home screen on VVX 411 phone



1. Press .

Access the Calls Screen

You can access the Calls screen when you have one held call or an active and held call in progress on your phone.

The Calls screen is automatically displayed when you have an active call and one or more held calls on your phone. The total number of calls is displayed on your line. If you have multiple lines on your phone, the calls display under the associated line, as shown next.

Calls screen on VVX 411 phone

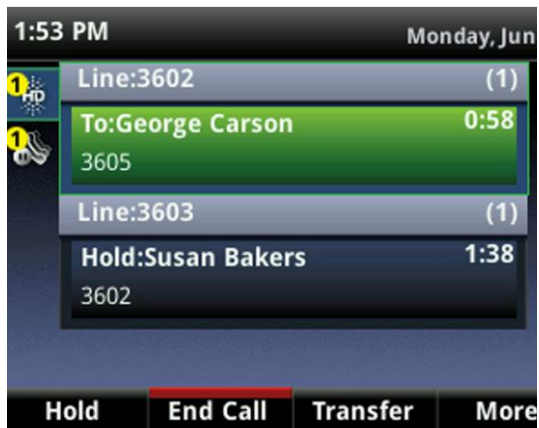

1. During a call, the following:
 - Press the Home key .
 - During a call, select the Lines soft key.

Access the Lines Screen

The Lines screen is the default screen when your phone is not in use.

When you have multiple calls on your phone, the number of calls is displayed next to the line number. You can view your phone lines, favorites, and soft keys on the Lines screen, as shown next.

On VVX 411 phone, you can also view active call and incoming call information in the status bar on the Lines screen, if enabled by your administrator, as shown next.

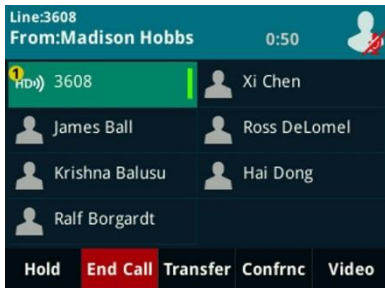



1. Do one of the following:
 - Press the Home key .
 - During a call, select the Lines soft key.

Access the Active Call Screen

The screen is displayed when you place a call and when an active call is in progress. When an active call is in progress, the name and number of the contact you are talking with and the duration of the call is displayed. In the Active Call screen, you can hold, end, transfer a call, or set up a conference call.

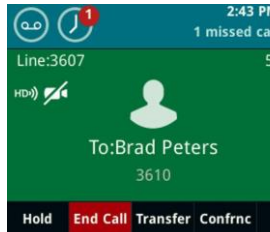
Active Call screen on VVX 411 phone



1. Do one of the following:
 - Place a call.
 - Press the Home key  during an active call.



Switch Among Phone Screens

You can see any phone screen by pressing the Home key  or swiping your finger from right to left on the touchscreen. Although you can access any phone screen from whatever screen you are on, certain screens are only accessible if your phone is idle or has one or more calls in progress.

You can access these screens in the following scenarios:

- If your phone is not in use, you can access the Home and Lines screens.
- If your phone has an active call, you can access all screens.
- If your phone has one active call only, you can access the Home, Lines, and Active Call screens.
- If your phone has multiple calls, or one held call, you can access the Home, Lines, and Calls screens.
- If your phone is off-hook but not in a call, you can access Home and Lines screens.























Procedure

1. Do one of the following:
 - From the Home screen, press  to display either the Lines, Calls, or Active Call screen.
The Calls and Active Call screen display only when an active or held call is in progress on your phone.
 - Press the Home key  to display the Home screen from the Lines, Calls, or Active Call screen.
 - Press the Lines soft key to access the Lines screen from the Calls or New Call screen.
 - Press the Calls soft key to access the Calls screen from the Lines screen.
 - When off-hook, press the New Call soft key to access the Lines screen.

Icons and Status Indicators

VVX 411 phones have various icons and status indicators that display the status of the phone whether you are in a call or the phone is idle and not in use.

The following table displays the phone icons and status indicators that display on VVX 411 phones.

Icon	Description	Icon	Description
	Registered line		Phone warning
	Unregistered line		Login credentials invalid
	Placing a call		Shared line
	Active call using Polycom HD Voice		USB flash drive attached (VVX 401/411 only)
	Held Call		Call forwarding enabled
	Incoming call		New message
	Active conference		Presence status (Available)
	Placed call		Presence status (Busy or In a Call)
	Received call		Presence status (Away)
	Missed call		Presence status (Do Not Disturb)
	Favorite		Presence status (Offline)
	Do Not Disturb enabled		Presence status (Unknown)

Audio Calls



Placing and Answering Audio Calls

VVX 411 phones can manage a maximum of 24 active, incoming, and held audio calls at a time. However, you can have only one active call in progress with numerous other incoming calls or calls on hold on all phones. Additionally, your system administrator can set up your phone to have up to six lines with unique extension numbers or the same extension number as other lines on your network.



Placing Audio Calls

You can place calls on a VVX 411 phone in numerous ways, including local and international calls, calls from Recent Calls or directories, calls to contacts or favorites.

Place a Call from the Dialer

The Dialer enables you to enter a number to place a call and displays a list of previously placed calls. As you enter numbers, the Dialer displays a list of similar numbers in your directory. Select a match to automatically enter the number.

Note: Your system administrator can set up your phone to automatically place the call after you enter a certain number of digits. If a call is placed before you enter all the digits, add the number to your Contact Directory and dial the number from the Contact Information screen.

1. Do one of the following:
 - Start typing a phone number.
 - Select New Call.
 - Press a line key.
 - Pick up the handset, press , or press .
2. Enter a number or select a recent contact.
3. Select Dial

Place an International Call

You can place calls to international phone numbers on a VVX 411 phone.

On the dialpad, quickly press the star key * twice.

1. A plus sign + is displayed.
2. Enter the phone number with the country code and press **Dial**

Place a Call from Recent Calls

You can place calls to contacts from the Recent Calls list, which contains calls that were recently placed, answered, or missed.

1. Do one of the following:



- On VVX 411 phones, navigate to Directories > Recent Calls.
2. From the Calls List screen, select a contact and select Dial.

Calling Favorites

You can call your favorites from the Favorites list or by selecting a favorite on your Home or Lines screen.

Call Favorites from the Favorites List

When you add a contact as a favorite, the contact is added to your Favorites list. You can call contacts directly from the Favourites list

1. Select New Call.
2. From the Dialer, select Favorites.
3. Select a favorite, and select Dial.

Call Favorites from the Home or Lines Screen

You can quickly call favorites from the Home or Lines screen

1. Do one of the following:
 - On VVX 411 phones, press a line key associated with a favorite on the Lines screen.

Calling Contacts from the Directory

You can search for and call contacts in your Contact Directory, the Corporate Directory, and the BroadSoft Directory.

Call a Contact from a Directory

You can place a call to a contact directly from your directory or you can select contacts in your directory to call from the New Call screen.

1. Do one of the following:
 - Select Directories.
 - Navigate to New Call > Directory.
2. Choose a directory.
3. From your directory, select or search for a contact.
4. Select the contact's phone number.
5. Select Dial.

Call a Contact from the Directory Search Screen

You can search for and call contacts from the Search screen in your directory.

1. Navigate to Directories and select a directory.
2. Select Search, enter your contact's first or last name, and select Search.
3. Select your contact.
4. In the Contact Information screen, select the contact's number, and select Dial.

Redial a Number

Your phone automatically keeps a record of all calls placed. You can recall the last contact you called using redial, if enabled by your system administrator

1. Do one of the following:
 - Select Redial on the Home screen.
 - Press the Redial soft key.

Redial a Contact when the Contact is Available

When you place a call to a contact and the contact's line is unavailable due to an unregistered line or a service outage, a notification displays on your phone when the contact's line is available again. You can choose to redial the contact or dismiss the notification.

Check with your system administrator to find out if this feature is available on your phone.

1. When the contact availability notification displays, select Dial.

Answering Audio Calls

When you receive an incoming call on a VVX business media phone, you can choose to answer the call in various ways, including answering calls automatically, in the Incoming Calls screen, in the Calls screen, and during a call.



Answer an Incoming Call

When you receive an incoming call, the phone rings and an Incoming Call screen is displayed, as shown next. In the Incoming Call screen, you can choose to answer or reject the incoming call.

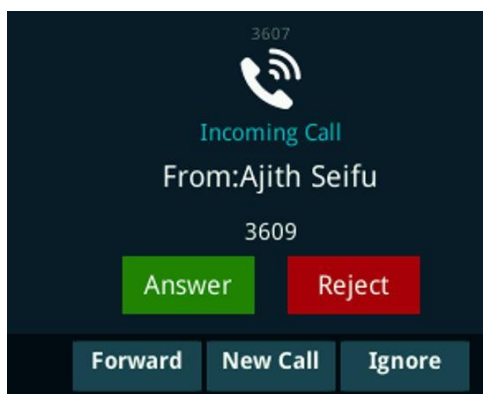
Incoming Call window



Note: Your system administrator can enable the screen to flash bright orange when you have an incoming call. The screen continues to flash until the incoming call is displayed in the Home or Calls screen. For more information about this feature, contact your system administrator.

1. Do one of the following:
 - Pick up the handset.
 - Press  or select Answer.
 - Press .

After you answer the incoming call, the call becomes active.

Answer a Call from the Calls Screen

When you don't answer an incoming call within 10 seconds, the Incoming Call screen disappears and the Calls screen is displayed.

1. Select the incoming call, and select Answer.

If your phone is locked, you must enter a user password or PIN before answering the call.

Answer a Call When in a Call

When you are in an active call and an incoming call arrives on the same or a different line, a call waiting tone beeps, and the Incoming Call screen is displayed.



If you don't answer the call within 10 seconds, the Incoming Call screen disappears, and the Calls screen is displayed.



1. Select Answer.



The active call is placed on hold, and the incoming call becomes active.

Switch Among the Handset, Headset, and Speakerphone

You can place and answer calls on your phone using the handset, headset, or speakerphone, and you can alternate among the three modes during calls, if available.



When using the speakerphone, the Speakerphone key  glows green. When using the headset, the Headset key  glows green if an analog headset is connected or blue if a USB headset is connected.

1. During a call, pick up the handset, press the Headset key  or press the Speakerphone key .

For example, if you're using the handset, press the Headset key  to switch to the headset, or press the Speakerphone key  to switch to the speakerphone.

Mute and Unmute Audio

You can mute the microphone so other parties cannot hear you. Microphone Mute applies to the handset, headset, and speakerphone. You can still hear all other parties when you mute your microphone. When your audio is muted, the Mute icon is displayed and the Mute key glows red, excluding VVX 101 and 201 phones.

1. During a call, including a conference call, press . The other parties cannot hear you.
2. Press  again to unmute the microphone.

Holding and Resuming Calls

When you are in a call, you can place an active audio call on hold and resume the call. You can place any active call on hold.

Hold a Call

1. During an active call, select **Hold**.

If you're in the Calls screen, select the call first.

A hold icon  is displayed on the line of the held call, and a red LED light flashes on the line key

Resume a Call

You can view and resume all held calls on the phone.

1. Do one of the following:
 - Select **Resume**.
 - From the Calls screen, select the call and select **Resume**.

Ending Calls

You can end active calls at any time, however, you must resume held calls before you can end the call.

End an Active Audio Call

You can end an active call on your phone at any time.

1. Do one of the following:
2. Place the handset on the cradle.

3. Press End Call.
4. In the Calls screen, highlight the call and press End Call.

End a Held Call

You cannot end calls that are on hold. You must resume held calls before ending them.

1. From the Calls screen, select the held call and press Resume > End Call.

Transferring Calls

You can transfer active or held calls to another person using the following transfer types:

- Blind transfer—Transfers the call directly to another line without speaking with the other party first.
- Consultative transfer—Enables you to speak with the other party before completing the transfer.

Choose a Default Transfer Type

You can choose a default transfer type to use for all calls.

When you choose a default transfer type, the phone uses the selected transfer type for all calls. Consultative is the default transfer type.

1. Navigate to Settings > Basic > Preferences.
2. Select Default Transfer Type and choose a transfer type. The selected transfer type is used for all calls.

Transfer a Call

You can transfer a call to another contact and choose the transfer type you want to use for the call.

1. During a call, do one of the following
 - Press Transfer to use the default transfer type.
 - Press and hold Transfer to use the non-default transfer type.
For example, if Blind is the default, press and hold Transfer to perform a Consultative transfer.
 - Press Transfer > More, and select Blind or Consultative.
Depending on the default transfer type, either the Blind or Consultative option displays. For example, if the default transfer type is Blind, then you can select Consultative.
2. Dial a number or choose a contact from the Recent Calls or a directory. If the transfer type is set to Blind, the call is transferred immediately.
3. If the transfer type is set to Consultative, select Transfer after speaking with your contact.

Cancel a Transfer

If a contact does not answer the transfer or you want to remain speaking with the contact on your line, you can cancel the transfer before it is complete.

1. Select Cancel.

The call is not transferred and becomes active.

Managing Calls

On VVX 411 phones, you can see the number of calls on the line from the Lines screen, as shown next. A green light on the line key indicates a line with an active call, and a red light indicates a line with one or more held calls.

Multiple Calls on phone lines on the Lines screen

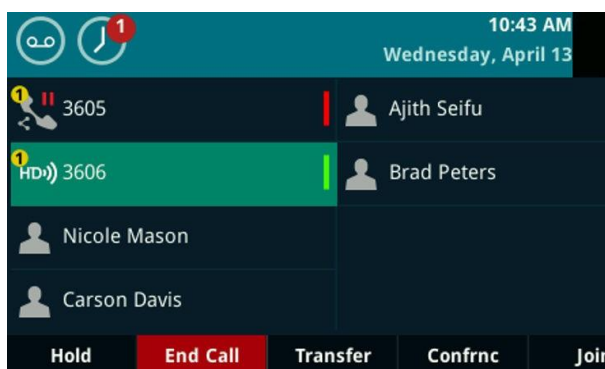

Display Calls from the Lines Screen

You can display the calls for each line from the Lines screen.

When you select a phone line that has a held call, the first held call on that line is automatically resumed, even if you already have an active call on a different line.

1. Do the following:
 - Press and hold the line key.

Display Calls from the Calls Screen

You can view multiple calls on your line from the Calls screen.

1. Do the following:
 - From the Lines or Home screen, press .

The Calls screen is displayed with the list of active and held calls for each line on the phone.

Manage a Call from the Calls Screen

From the Calls screen, you can manage a call by holding, resuming, or transferring the call.

1. Select a call.



2. Do one of the following:
 - Select Hold to place an active call on hold.
 - Select Resume to make a held call active.
 - Select End Call to end a call with a contact. You can end active calls only, so resume the held call first before ending it.
 - Select Transfer to send the call to another contact.
 - Select Conference to initiate a conference call.

Ignoring or Rejecting Incoming Calls

When you receive an incoming call, you can choose to ignore or reject the call instead of answering. You can reject or ignore incoming calls, reject incoming calls from a specific contact, or enable Do Not Disturb to reject all calls for a brief time period.

Note: You cannot reject calls on shared lines. You can only silence the ringer.

Ignore or Silence an Incoming Call

You can ignore or silence a call to stop your phone from ringing. Even if you ignore the call and silence the ringer, an incoming call notification continues to display on your phone.

1. From the Incoming Call screen, do one of the following:
 - Select Ignore for private lines.
 - Select Silence for shared lines.

The Incoming Call screen disappears, your phone stops ringing, and either the Home or Calls screen is displayed.

Reject Incoming Calls

You can reject a call and send the call directly to voicemail. Rejected calls display in the Missed Calls list in your Recent Calls list. Rejecting calls is not available for shared lines.

1. From the Incoming Call screen, select
Reject. The call goes directly
to voicemail

Reject Calls from a Contact

You can send incoming calls from a particular contact directly to your voicemail.

1. Navigate to Directories > Contact Directory.
2. From your Contact Directory, select a contact.
3. From the Contact Information screen, select Edit
4. From the **Edit Contact** screen, select **Auto Reject > Enabled** and select Save. Calls from the contact are sent directly to voicemail when the contact calls.

Rejecting Calls with Do Not Disturb

Do Not Disturb (DND) enables you to set your phone to automatically reject calls when you do not want to be interrupted.

When you enable Do Not Disturb (DND), the following occurs:

- The DND icon  displays in the status bar.
- When the phone is idle, the DND icon is displayed next to your phone line on the Lines screen.
- If you have new messages or call forwarding is enabled, the messages or forwarding icon is displayed instead of the DND icon.
- The message “Do Not Disturb” is displayed in the status bar on all phones.
- The DND icon on the Home screen changes from



Note: When you set your presence status to Do Not Disturb, as well as enable DND for your phone, a message stating that your status is set to Do Not Disturb scrolls under the time display, and the DND icon does not display in the status bar.

Enable Do Not Disturb

You can enable DND to prevent your phone from ringing and to send all incoming calls directly to voicemail. All calls you receive while DND is enabled are logged in the Recent Calls list.

Enabling DND on shared lines disables ringing only. A visual notification of the call still displays, and you have the option to answer or ignore the call.

Note: When you are signed into a host phone as a guest, you can only enable Do Not Disturb if the server-based Do Not Disturb feature is enabled on the phone. If server-based DND is disabled on the phone, you cannot use DND on the host phone. Contact your system administrator for help enabling this feature.

1. Select **DND**.

Reject Calls with Do Not Disturb on Multiple Lines

By default, the Do Not Disturb feature applies to all lines on your phone. Your system administrator can set up your phone so that you can enable the feature on a per-line basis.

1. Select **DND**.
2. Select **Set All** to enable DND for all lines.

Reject Calls with Do Not Disturb on One Line

If you have more than one line, you can choose to enable DND for a particular line and not all lines, if enabled.



1. Select **DND**.
2. From the **Line Select** screen, select a line.
3. From the **Do Not Disturb** screen, select **Enable**.

Disable Do Not Disturb

You can disable DND when you are ready to resume receiving calls again.

Procedure

1. Select **DND**.

Redirecting Incoming Calls

You can redirect incoming calls by forwarding an incoming call to a contact, forwarding all incoming calls to a contact, or diverting calls from a specific contact to another contact.

Forwarding Incoming Calls to a Contact

You can choose to forward an incoming call to a contact or forward all incoming calls to one of your contacts.

Note: When you are signed into a host phone as a guest, you can only forward calls if the server-based Call Forwarding feature is enabled. If server-based Call Forwarding is disabled, you cannot forward calls to a contact from the host phone. Contact your system administrator for help enabling this feature.

Forward an Incoming Call to a Contact

You can forward an incoming call directly to a contact without answering the call. You cannot forward calls in this way on shared lines.

1. In the Incoming Call screen, select Forward.
2. From the Call Forwarding screen, enter the forwarding number, and select Forward.

Forward All Incoming Calls to a Contact

You can set up your phone to forward all incoming calls to a contact using one of the following forwarding types:

- Always—Forwards all incoming calls.
- No Answer—Forwards all unanswered incoming calls.
- Busy—Forwards incoming calls when you're in a call.



For shared lines, you can only choose Always as your forwarding type; the other forwarding options are not available for shared lines.

1. Select Forward or navigate to Settings > Features > Forward.
2. If your phone has multiple lines, select a line.
3. On the Forwarding Type Select screen, select a forwarding type.
4. Enter a contact's number or IP address, if enabled, and select Enable.
5. If you selected the No Answer option, enter the number of rings before the call is forwarded.

The forwarding number or name of the contact you chose scrolls in the status bar. When you select Always as your forwarding option, the Forwarding icon is displayed on the line.

Disable Call Forwarding

You can disable call forwarding when you no longer want to forward your calls

1. Select Forward.
2. If your phone has multiple lines, select a line.
3. From the Forwarding Type Select screen, select your forwarding type, and select Disable.

Divert Calls to a Contact

You can divert all incoming calls from a particular contact to another contact.

1. Select Directories > Contact Directory.
2. From the Contact Directory, select a contact.
3. From the Contact Information screen, select Edit
4. From the Edit Contact screen, select Divert Contact, and enter a contact's number.
5. Select **Auto Divert > Enabled**.
6. Select **Save**.

Conference Calls

You can initiate audio conference calls with various contacts on your VVX 411 phone. When you initiate a conference call, you can hear audio for two or more contacts, manage conference participants, and join calls into a conference or split a conference into individual calls.

Tips for Conference Calls

When you are in a conference call, follow these tips:

- Use the handset or a headset if you're in an open environment.
- Mute your microphone when you are not speaking, especially in noisy environments.
- Avoid tapping or rustling papers near the microphone.

- Speak in your normal voice without shouting.

Audio Conference Calls

You can initiate an audio conference call with two contacts and hold, resume, or split a conference call on your VVX 411 phone.

VVX 411 phones can manage a maximum of 12 active or held conference calls at a time. However, you can have only one active conference call in progress with numerous other conference calls on hold.

If your system administrator enables the Conference Management feature on your phone, you can manage each participant in the call. With the Conference Management feature, you can mute, hold, and remove individual participants in a conference call.

Initiate a Conference Call

You can initiate a conference by calling two people and selecting the Conference soft key or hard key.

Note: When your phone is set up for single key press conferences, you do not need to tap the Conference soft key or press the Conference key a second time to join parties to a conference call.

1. Call a contact.
2. After the contact answers, select the Conference soft key.
The call is held.
3. Enter another contact's number or select a contact from the directory or the call lists.
4. When the contact answers, select the Conference soft key.
All call participants are added to a conference call.

Join Calls to Create a Conference Call

You can join one active call and one held call into a conference call. If you have more than one call on hold, you can select a held call to join into a conference call with the active call.

1. Do one of the following:
 - When you have an active call and a held call, select the Join soft key.
 - When you have an active call and more than one held call, select a held call and then select the Join soft key.

The active call and the selected held call are joined into a conference. If you have multiple held calls, the other held calls on the line remain held.



End a Conference Call

By default, when you end a conference call, your connection to the call ends and the other participants in the conference remain in the call.

However, your system administrator can set up your phone so that all connections terminate when you end a conference call.

1. During a conference call, select End Call.

Hold a Conference Call

When you place a conference call on hold, you place all conference participants on hold.

1. Select **Hold**.

Resume a Conference Call

Resuming a held conference call enables all participants to hear the audio of everyone on the call.

1. Select **Resume**.

Split a Conference Call

When you split a conference, you end the conference call and place the other two people on hold. You can split an active or held conference call. After you split a conference call, you can resume one of the held calls.

1. During a conference call, select the Split soft key.

The conference call ends and the two participants are held in two separate calls.

Manage Conference Call Participants

If your system administrator enables the Conference Management feature on your phone, you can manage conference call participants in the following ways:

- Mute a participant.
 - Hold a participant.
 - Remove a participant from the conference.
 - List information about a participant, such as the participant's name, number, and call details, including whether the call is muted, held, or is video-enabled.
1. Initiate a conference call.
 2. Select Manage.

If you're in the Calls screen, highlight the conference first.

3. Select the participant you want to manage.
4. Do one of the following:
 - Select Far Mute to mute the participant. The muted participant can hear everyone, but no one can hear the muted participant.
 - Select Hold to hold the participant. The held participant cannot hear anyone, and no one can hear the held participant.
 - Select Remove to remove the participant from the conference, end the conference call, and create an active call between you and the participant still in the call.
 - Select Information to view information about the participant's call status. When you select Information, a screen is displayed listing the person's information, as shown next.

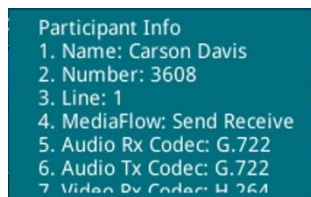

5. Select **Back** to exit the conference management function.

Call Lists and Directories

Recent Calls

The Recent Calls list on VVX 411 phones includes missed, received, and placed calls. Each list holds up to 100 entries.

You can perform the following tasks from the Recent Calls list:

- Sort, order, and filter calls. By default, the list displays all call types with the most recent call displaying first.
- Remove calls from the list.
- Select a call record to view call details.
- Select a call record to automatically call a contact.

View Recent Calls

In the Recent Calls list, you can view a list of up to 100 missed, received, and placed call entries.

1. Do one of the following:
 - Navigate to Directories > Recent Calls.



Sort Recent Call Entries

You can customize the Recent Calls list to view calls by call type, time, and call name.

When you sort calls by the time of the call, you can order them in ascending (oldest call first) or descending (most recent call first) order. When you sort calls by name, you can order them in ascending (alphabetical) or descending (reverse-alphabetical) order

1. Select **Sort**
2. Under **Sort**, choose **Time** or **Name**.
3. Under **Order**, choose **Ascending** or **Descending**.

Sort Entries by Call Type

When you filter calls, you can choose to display only missed, received, or placed calls. You can also choose to display all call types (the default).

Note: You cannot save your filtered call list results. If you filter your Recent Calls list so that only a certain call type displays, the next time you display the list, all call types display in the default filter.

1. Select Type
2. Choose Missed Calls, Received Calls, or Placed Calls.

Edit a Recent Call Entry

You can edit a contact's phone number stored in your Recent Calls list before returning the contact's call.

1. Select **Info**
2. Select **Edit**
3. Edit the number and select Dial

Delete a Recent Call Entry

You can delete any recent call entry from the Recent Calls list.

1. Select **Info**
2. Select **Delete**

Save a Recent Call Entry

You can save a recent call entry to the Contact Directory.

1. Select **Info**
2. From the **Call Details** screen, select **Save**.
If the person is already in your Contact Directory but is not a favorite, **Add to Favorites** is displayed.



View Call Details

In the Recent Calls list, you can view call details, edit call details before calling a contact, save a contact to your directory, and delete call entries.

1. Select **Info**

Contact Directory

You can store a large number of contacts in your phone's Contact Directory, as well as add additional contacts, view and update a contact's information, and delete contacts from the directory.

Contact your system administrator for the exact number of contacts you can store in the Contact Directory for your phone model.

Note: If you cannot add or edit contacts in the Contact Directory, your system administrator has set the directory as read-only. Contact your system administrator for assistance making any changes to the contacts stored in the directory.

Search for a Contact in the Contact Directory

You can search for your desired contact in the Contact Directory.

1. Navigate to Directories > Contact Directory.
2. In the Contact Directory, select Search.
3. In the search field, enter your search criteria and select Submit.

Add a Contact to the Contact Directory

When you add a contact to your Contact directory, you can choose how much information you want to enter for your contact. You are required to only enter a contact number for each new contact.

The following is a list of information you can enter for each contact:

- First and Last Name—The name of your contact
- Contact—Your contact's phone number
- Job Title—Your contact's position

- Email—Your contact's personal or work email address
- Favorite Index—An index number that displays in your Favorites list
- Label—A label or title for your contact

Note: If your phone does not display all of these contact fields, contact your system administrator. The only required field in the Contact Directory is the Contact field, which includes the contact's phone number.

1. Navigate to Directories > Contact Directory.



2. In the Contact Directory, select **Add**
3. From the Add Contact screen, enter your contact's information in the available fields.
You are required to only enter a number in the Contact field when adding a new contact to the directory. You can choose to enter additional information.
4. Select **Save**.

View Contact Information

From your Contact Directory, you can view information, such as name and phone number, for any contacts saved to the directory. You can also view additional information, such as a job title, label, or email address

1. Navigate to Directories > Contact Directory.
2. From the Contact Directory, select a contact.

Update a Contact's Information

After you add a contact to your Contact Directory, you can update the contact's information

1. From the **Contact Directory**, select a contact.
2. From the **Contact Information** screen, do one of the following:
 - Select **Edit**.
 - Select **Info > Edit**.
3. From the **Edit Contact** screen, update the contact's information.
4. Select **Save**.

Delete a Contact from the Contact Directory

You can delete any contact from the Contact Director

1. Navigate to Directories > Contact Directory.
2. From the Contact Directory, select a contact.
3. From the Contact Information screen, do one of the following:
 - Select **Delete**.
 - Select **Info > Delete**.

A confirmation message is displayed, confirming that you want to delete the contact.

4. Select **Yes** to delete the contact.

Corporate Directory



Your system administrator can set up your phone so that you can access a Corporate Directory, which lists contacts and groups within your company.

However, you cannot update the Corporate Directory, and your system administrator determines which contacts you can see. Check with your system administrator to find out if this feature is available.

Note: You may need to enter your user credentials to access the directory for the first time, if set by your system administrator.

Searching the Corporate Directory

In the Corporate Directory, you can perform a quick or advanced contact search.

Perform a Quick Search of the Corporate Directory

A quick search enables you to search for contacts using either their first name or last name.

1. Navigate to Directories > Corporate Directory.
2. In the search field, enter your search criteria and select Submit.
3. Select a contact and select View to view the contact's information.

Perform an Advanced Search of the Corporate Directory

An advanced search enables you to choose to search for contacts by first name, last name, or phone number.

1. Navigate to Directories > Corporate Directory.
2. In the Corporate Directory, select AdvFind.
3. In the search field, enter your search criteria and select Submit.
4. Select a contact and select View to view the contact's information.

Save Corporate Directory Search Results

Save your last search results if you would like to see them displayed in the Corporate Directory the next time you view it.

1. Navigate to **Settings > Basic > Preferences > Corporate Directory > View Persistency**.
2. From the **View Persistency** screen, select **Enabled**.

Each time you view the Corporate Directory, your last search results automatically display.

Clear Corporate Directory Search Results



After you search for a contact, you can clear your search results and start a new search.

1. On the Search screen, select Clear.

Add Corporate Directory Contacts to the Contact Directory

You can add contacts in the Corporate Directory to the Contact Directory.

When you save a Corporate Directory contact to the Contact Directory, the first name, last name, and phone number of the contact are automatically saved to the directory. You can add additional contact information after the contact is saved to the directory.

1. In the Corporate Directory, search for a contact.
2. From the search results, select the contact and select View.
3. Select Save
4. Enter any additional contact information and select Save.

Favorites and Contact Lists

Managing Favourites

Favorites are the contacts in your Contact Directory that you will call most often. You can add contacts as favorites from the Contact Directory, designate an index number for favorites, view favorites on the Home or Lines screen depending on your phone, and delete favorites.

Add Favourites

Contacts that you add as favorites display in the Lines screen on VVX 411 phones, and in the Favorites list on all VVX 411 phones. A star is displayed for contacts saved as favorites.

1. Navigate to Directories > Contact Directory.
2. From your Contact Directory, select a contact.
3. Select Add or Add to Favorites.
A notification is displayed asking if you want to automatically accept the next available index number or manually enter your own.
4. Select Yes to automatically accept an index number or select Edit Index to enter a unique index number.

You can enter a number up to 9999 for VVX 411 phones.

Viewing Favourites

You can view favorites in your Favorites list in the Directory or the New Call screen. Favorites display consecutively according to their index number. The contact with the lowest number is displayed first.

View Favourites

You can view favorites in the Favorites lists from the New Call screen.

1. Select **New Call > Favorites**.



View Favorites from the Lines Screen

You can view a list of favorites on the Lines screen.

1. From the **Home** screen, press .

Reorder Favorites

You can change the order in which your favorites display on the Home or Lines screen.

1. From your **Contact Directory**, select a contact.
2. From the **Contact Information** screen, select **Edit**
3. From the **Edit Contact** screen, select **Favorite Index** and enter a new favorite index number.
4. Select **Save**.

Delete Favorites

You can delete favorites to make room for new favorites.

1. From your Contact Directory, select the contact.
2. From the Contact Information screen, select Edit
3. From the Edit Contact screen, select Favorite Index, and delete the favorite index number.
4. Select Save.

Tip: To quickly delete a contact, on the Lines screen, press and hold the favorite until the Contact Information screen is displayed. Select Delete The contact remains in your directory, but is no longer a favorite.

Phone Accessories and Computer Applications



Using a Headset with Your Phone

You can connect a headset to your VVX phone and use the headset to place and answer calls, handle all calls using a headset, and use electronic hookswitch (EHS).

You can connect an analog headset to all VVX 411 phones or a USB headset.

Note: For information on your headset's features, as well as how to sync your headset with your phone, see your headset's documentation.

Connecting a Headset

Your phone does the following when connected to analog and USB headsets:

- When an analog headset is connected and in use, the headset key glows green.
- When a USB headset is connected and in use, the headset key glows blue.
- When both an analog and USB headset are connected, the USB headset is used automatically for all calls.
- When two USB headsets are connected, the headset you connected first is used automatically for all calls.

After you connect a headset to your phone, you can set up your phone to use the headset automatically when answering and placing calls.

Note: If your phone does not detect the USB headset when you attach it to your phone, the USB port on your phone may be disabled. Contact your system administrator.

Use Your Headset for All Calls

You can set up your phone so that all incoming and outgoing calls automatically use your headset. To use this feature, you must enable and activate Headset Memory Mode

1. Navigate to **Settings > Basic > Preferences > Headset > Headset Memory**.
2. From the **Headset Memory Mode** screen, select **Enabled**.
3. Press the headset key twice.

The headset key flashes to indicate that Headset Memory Mode is now activated. All calls placed or answered on your phone use your headset automatically.

Note: If you or your contacts experience audio or echo issues during calls, such as feedback of your voice or of their own voice, you need to enable echo cancellation on your phone.

Reactivate Headset Memory Mode

Switching to the speakerphone or the handset deactivates Headset Memory Mode

1. Press the headset key twice.

Using Electronic Hookswitch

When you use a headset that supports electronic hookswitch (EHS), you can place, answer, and end calls by using the controls on your headset. To use EHS, you need a headset that includes a serial control interface in addition to the standard analog headset jack (RJ-9) interface. The serial control interface requires an EHS adapter that you can purchase from your headset manufacturer.

Headsets that support EHS include a base unit that connects to your phone. The headset connects to the base unit wirelessly, which enables you to use your headset even if you're some distance away from your phone. Typically, you can work wirelessly up to 300 feet (91 meters) from your phone and still use the EHS controls. Check with your headset's user guide for the precise range restrictions.

Setting the Headset Base Unit Options

Before you connect your headset to your phone and use EHS, you need to set the following options for your specific headset model:

- For Jabra headsets, change the headset mode to DHSG on the headset base unit. For details, refer to your headset documentation or contact Jabra support.
- For Plantronics headsets, change the coarse receive level to 3 and the transmit level to B on the headset base unit. For details, refer to the guide that comes with your headset.
- For Sennheiser headsets, set the first DIP switch labeled 1 (DHSG) to the down position on the back of the headset base unit. For additional details, see your headset's documentation or contact Sennheiser support.

Enable Electronic Hookswitch

After you set the base unit options for your headset and connect your headset to your phone, you can enable EHS.

1. Connect your headset and EHS adapter to your phone.
See the Quick Start Guide for your phone on Polycom Voice Support for information on connecting a headset to your phone.
2. Navigate to Settings > Basic > Preferences > Headset > Hookswitch Mode.
3. Select one of the below modes for your specific headset:
 - Choose Jabra if an EHS-compatible Jabra headset is attached with an EHS cable or adapter.
 - Choose Plantronics if an EHS-compatible Plantronics headset is attached with an EHS cable or adapter.
 - Choose Sennheiser if an EHS-compatible Sennheiser headset is attached with an EHS cable or adapter. If your phone does not have a menu selection for Sennheiser, select Jabra instead.
 - Choose Regular Mode (default) if another headset is attached.

Change the Headset Mode

Headsets that come with a docking station have two modes: soft phone and desk phone mode. To control your phone using your headset, the headset must be in soft phone mode. If you cannot operate the phone from your headset, it is possible your headset is in desk phone mode



1. Press and hold the headset hookswitch until you hear a sound or message on the headset.

Controlling Calls with Electronic Hookswitch

After you have followed the procedures for connecting your headset and enabled EHS, you can use the controls on your headset to answer, mute, and end calls. If supported on your headset, you can also place calls on hold. See your headset's user documentation for information on controlling calls from your headset.

When you are in an active call and you receive an incoming call, you cannot use the hookswitch control on your headset to place the active call on hold and answer the incoming call. Pressing the hookswitch control on the headset ends the active call and answers the incoming call. To place the existing call on hold and answer the incoming call, answer the call on your phone.

Disconnect Your Headset

If you want to disconnect or change your headset, you need to properly detach your headset from your phone.

1. Navigate to **Settings > Basic > Preferences > Headset > Hookswitch Mode**.
2. Select **Regular Mode**.
3. Remove the EHS adapter from the serial port on the back of the phone.

Accessibility Features

Polycom products include a number of features to accommodate any type of user. The following sections describe accessibility features for hearing, vision, or mobility-impaired users available on VVX Business Media Phones.

Features for Hearing-Impaired Users

Polycom phones include many features that enable users with hearing impairments to use various features on the phone.

The following table lists the accessibility features for hearing-impaired users.

Accessibility Features for Hearing-Impaired Users

Accessibility Feature	Description
Visual message indicators	An indicator light on the phone indicates that new messages are waiting. Icons on the screen also indicate that the phone has new messages.
Adjustable ring tone and volume	You can choose from a variety of ring tones for the phone. You can also change the volume of the ringer to suit your needs and choose different ring
Adjustable Call Volume	While in a call, you can raise or lower the volume of the audio from the far end and of any other sounds on the device.



Visual notifications	Status and icon indicators let you know when calls are incoming, outgoing, active, or held. Indicators can also indicate the device's status and if
Visual ringing	Certain VVX models have visual ringing that enables the screen to flash bright orange for incoming calls (contact your system administrator to enable this
Electronic hookswitch	If you use a headset that supports electronic hookswitch (EHS), you can use the controls on your headset to answer and end calls. Additionally, you may be able to mute calls and control volume from

Accessibility Feature	Description
Headset Memory Mode	If you use a headset, you can set up your phone to use your headset for all calls.
Hearing Aid Compatible (HAC) handsets	All phones are Hearing Aid Compatible (HAC) and have telecoils that magnetically couple to most forms of wearable hearing aids per FCC section 508 (compliant to ADA Section 508 Recommendations:
TTY support	The phones supports commercial TTY devices such as Ultratec Superprint. Additionally, the phones provide acoustic coupled TTY support.

Features for Mobility-Impaired Users

Polycom phones include features that enable users with mobility impairments to perform various functions on the phone.

The following table lists the accessibility features for mobility-impaired users.

Accessibility Features for Mobility-Impaired Users

Accessibility Feature	Description
Auto-answer feature	You can enable the phone to auto-answer calls so you don't have to choose an option to answer a call.
Headset Memory Mode	If you use a headset, you can set up your phone to use your headset for all calls.



Large keys	The large keys on the phone console enable you to access phone features and functions.
Built-in speakerphone	A built-in speakerphone allows you to hear audio on the device without having to use a handset or headset.
Adjustable phone stand	You can adjust the phone stand to various angles so your phone sits at a comfortable angle on your desktop.
Polycom Desktop Connector application	You can use your computer's mouse and keyboard to enter information and navigate screens on your phone.

Features for Vision-Impaired and Blind Users

Polycom phones include various features that enable users with visual impairments to use many of the features on the phone.

The following table lists the accessibility features for visually-impaired and blind users.

Accessibility Features for Vision-Impaired and Blind Users

Accessibility Feature	Description
Adjustable backlight settings	You can change the brightness of the screen by adjusting backlight intensity settings.
Auto-answer feature	You can enable the phone to auto-answer calls so you don't have to choose an option to answer a call.
Tactile "5" key with raised bumps	The "5" key has two bumps that enable you to discern the position of other keys on the keypad.
Large keys	The large keys on the phone console enable you to access phone features and functions.
Physical line keys	VVX 300 series and 400 series phones have physical line keys that you can press to answer and
Physical feature keys	Many features on the phones are accessible by pressing feature keys on the phone console.
Tactile-discernible number, feature, and navigation keys	Keys on the phone console are discernible by their size and shape.
Illuminated feature keys	Many feature keys are illuminated when activated so you're alerted when a feature is enabled.



Microphone mute feature

The system plays an alert tone when the microphones are muted or unmuted using any of the Mute keys on the device or far-end system. The system plays an alert tone periodically if the device is muted for a set

General information

Important

- Access to Emergency Services is provided but calls including emergency calls to 999 or 112, made via WHC may not work in the event of power or broadband connection failure. These failures may be caused by reasons outside our control. Location information, provided to the emergency services, is limited to the location details entered into the system by your Service Provider; this may not be where the call was originated.

Safety information

- Do not open the handset or the base. This could expose you to high voltages or other risks. Contact your Service Provider for all repairs.

Cleaning

- Clean the handset and base with a damp (not wet) cloth, or an anti-static wipe. Never use household polish as this will damage the product. Never use a dry cloth as this may cause a static shock.

Environmental

- Do not expose to direct sunlight
- Do not stand your product on carpets or other surfaces which generate fibres, or place it in locations preventing the free flow of air over its surfaces
- Do not submerge any part of your product in water and do not use it in damp or humid conditions, such as bathrooms
- Do not expose your product to fire, explosive or other hazardous conditions
- There is a slight chance your phone could be damaged by an electrical storm.

Product disposal instructions

- The symbol shown here and on the product means that the product is classed as Electrical or Electronic Equipment and should not be disposed with other household or commercial waste at the end of its working life.
- The Waste of Electrical and Electronic Equipment (WEEE) Directive (2002/96/EC) has been put in place to recycle products using best available recovery and recycling techniques to minimize the impact on the environment, treat any hazardous substances and avoid the increasing landfill.
- Business users should contact their suppliers and check the terms and conditions of the purchase contract and ensure that this product is not mixed with other commercial waste for disposal.



Guarantee

- Your IP Phone is guaranteed for a period of 12 months from the date of purchase.
- Subject to the terms listed below, the guarantee will provide for the repair of, or at the Service Provider or its agent's discretion, the option to replace the Phone or any component thereof, (other than batteries), which is identified as faulty or below standard, or as a result of inferior workmanship or materials. Products over 28 days old from the date of purchase may be replaced with a refurbished or repaired product.

The conditions of this guarantee are:

- The guarantee shall only apply to defects that occur within the 12-month guarantee period
- Proof of purchase is provided
- The equipment is returned to your Service Provider or its agent as instructed
- This guarantee does not cover any faults or defects caused by accidents, misuse, fair wear and tear, neglect, tampering with the equipment, or any attempt at adjustment or repair other than through approved agents
- This guarantee does not affect your statutory rights.

